

# Parts & Electrical Information for Taxiway & Runway Signs

## XTL lighting systems

(Gray base 20W quartz halogen lamps)

**Certified to current FAA Advisory Circular 150/5345-44H**  
Specification for Runway and Taxiway Signs  
*View our Certificate of Conformance dated 12/3/2008*

### LUMACURVE XTL System

The LUMACURVE XTL system maintains a constant sign brightness in accordance with FAA A/C 150-5324-44 with appreciably higher efficiency relative to traditional lighting systems, and is available in new signs or in kit form for retrofit. This system ensures delivery of a constant voltage to quartz lamps regardless of constant current regulator (CCR) output to the primary circuit and operates on both high (2.8A - 6.6A) and medium (4.8A - 6.6A) intensity circuits without internal modification\*. The lamps authorized for use in this system are Standard Signs Inc P/N # "XTL Quartz" with 10v/20w Bipin quartz halogen lamp & custom ceramic adapter base. They are available directly from Standard Signs Inc.

### IMPORTANT!

The LUMACURVE XTL lighting system is designed exclusively for FAA styles 2 & 3 operation on a series circuit together with non-sign fixtures, such as edge lights, where the sign brightness control components are necessary to maintain constant sign brightness regardless of CCR step. Non-sign load must be present on the circuit for proper operation of this system. XTL Signs should NOT be installed on a circuit that powers only signs. For circuits dedicated to signs, please request LUMACURVE lighting systems designed for FAA style 5 operation.

### INSTALLATION:

System lamp voltage is factory set but we recommend that one sign per CCR be spot checked with a DC voltmeter after installation. Lamp voltage is read across the white and brown leads at the sign terminal strip on the light bar (P/N #CLT 8). If voltage varies from recommended settings (9.5V for Size 1 signs or 9.5V for sizes 2, 3, and 5), all signs on that circuit should be checked and adjusted. To adjust, turn the small screw in the upper left corner of the printed circuit board (PCB) controller(s) mounted on the inside of the end panel (P/N #CLT-4).

NOTE: The adjustment screw is designed only for fine-tuning and does not function as a dimmer.  
Signs must not be operated at less than 9.5 volts.

There is a 10-minute warm-up period for lamps to come to set voltage but sign brightness meets FAA specifications even at cold voltages. Approximate average sign brightness for a yellow sign (white is 25% brighter) at recommended voltages for FAA sign sizes 1, 2 & 3 are as follows:

Size 1	Size 2	Size 3
9.5V	9.5V	9.5V
15-16 FLT	18-19 FLT	18-19 FLT

\*Isolation transformer wattage requirements may vary for each application.

For further assistance please call 800-258-1997.



Only Lumacurves are backed by a  
**3 Year Warranty !**  
Contact customer service for details.

Copyright 2005 by STANDARD SIGNS, INC. ALL RIGHT RESERVED.

## STANDARD SIGNS, INC.

3190 East 65th Street, Cleveland, Ohio 44127, USA  
Phone: 800.258.1997 / 216.341-5611 Fax: 216.341.0652  
www.lumacurve.com

# LUMACURVE PARTS LIST

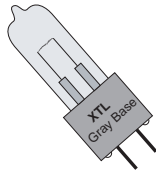

## XTL Lighting Systems (Gray Base 20W quartz halogen lamps)

Certified to current FAA Advisory Circular 150/5345-44H  
Specification for Runway and Taxiway Signs  
View our Certificate of Conformance dated 12/3/2008



Experience our exclusive "Wait-Less" service!  
Call by 10AM, complete signs & parts ship same day!  
No extra charge! Call 800.258.1997

Item	Description
1.	340/345 Turn Fasteners
2.	*CLT-2 Cover
3.	*CLT-3 Base
4.	*CLT-4 End Panel
5.	*CLT-5 Legend Panel <sup>1</sup>
6.	*CLT-6 Multi-Mode Insert
6A.	*CLT-6A Panel Spacer <sup>2</sup>
7.	*7-A Face Insert Channel <sup>1</sup>
8.	*8-A Lamp Socket Channel
9.	XTL Quartz XTL 20W Quartz Lamp
10.	E400A Lampholder
11.	480 Cable Clamp
12.	420 Terminal Strip
13.	420 Terminal Strip (section)
14A.	E411 Capacitor for E410
14B.	E611 Capacitor for E610
15A.	E410 PCB Controller, 50 Volt (1-4 lamps)
15B.	E610 PCB Controller, 75 Volt (1-8 lamps)
16.	E540 Bridge Rectifier 25A/600V
17.	CLT-19 Tether
18.	130 Slipfitter
19.	*140 Frangible Coupling (6" long)
20.	430 Cord & Plug
21.	15 Floor Flange
22.	Surge Protector Kit

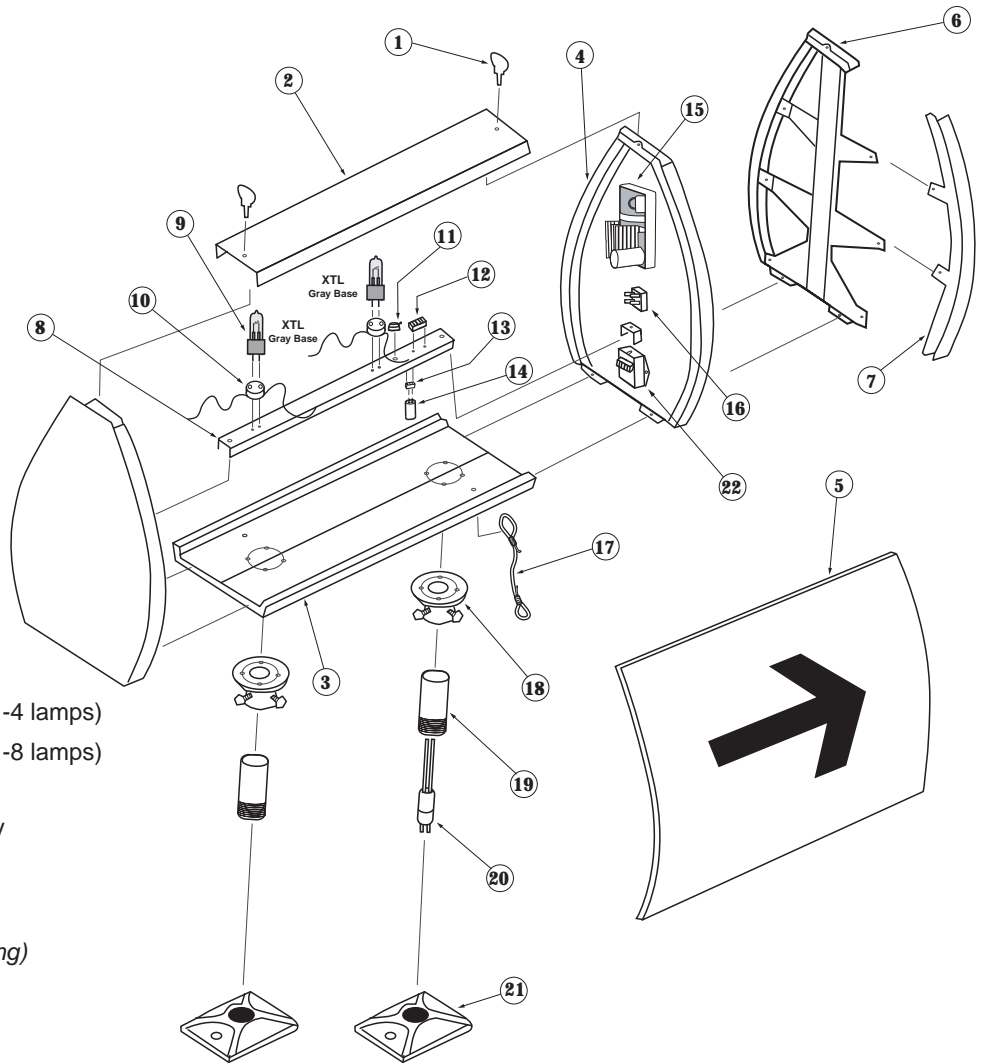

One lamp systems only require:

To help in placing your order:

\*Prefix part number with one of the following sign sizes: "S" (small/ size 1), "M" (medium/ size 2), "L" (large/ size 3 & 5)

<sup>1</sup> Specify one of the following sign types: L-858Y ("Y"ellow), L-858R ("R"ed), L-858L ("L"ocation), or Blank/ Black

<sup>2</sup> Size 3 only, 2 per module-not pictured