

Warning! For maintenance of previously installed equipment only!
 This system has not been certified to meet the latest FAA Advisory Circular 150/5345-44H

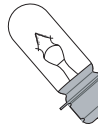

Parts & Electrical Information for Taxiway & Runway Signs



Style 2 lighting systems
 T10P 6.6A/45W incandescent & 45W/EXM quartz lamps

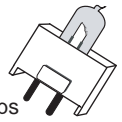

Making electrical adjustments:

There are one or more BRIGHTNESS CONTROL TRANSFORMERS in the LUMACURVE sign so that lighting will comply with the requirements of FAA Advisory Circular 150/5345-44. The transformer is wired according to the number of lamps in the sign. The higher tap in each case leads to the isolating transformer (along with the white lead). The lower tap leads to the lamp(s).

There is wiring diagram below showing the transformer lead color coding.

After installation, the current to the lamps must be checked with a "RMS" or "IRON VANE" ammeter.

(The current produced by airfield lighting regulators is non-sinesoidal.) Because of wave form variations in regulators, the factory setting might be too high (even over 6.6A) and severely shorten lamp life, or too low and the sign too dim. Required lamp inputs in amps are shown below for each size of sign:

Size S (FAA size 1) - 5.1 to 5.9A, Size M (FAA size 2) - 5.5 to 6.3A, Size L (FAA size 3 & 5) - 5.2 to 6.2A

Set the regulator on 4.8A and check the sign lamp current. If it is under the minimum shown above, first move the "isolating transformer" or the "lamp" tap (whichever one has an open step above it) up one step, then move the other tap (if necessary), to bring current as close as possible to above the minimum. Then set the regulator at 6.6A and make sure the lamp current is not over the maximum, although once the minimum is set, the maximum should fall in place. If it is over the maximum, make the minimal downward adjustment possible to bring lamp current under the maximum allowed.

Style 2 Lighting System

6.6A/45W Incandescent lamps									45W EXM Quartz lamps										
CAT#	Power Taps		Lamps	Watts	Amps	Volts	VA	PF	ISO Xfmr	CAT#	POWER TAPS		Lamps	Watts	Amps	Volts	VA	PF	ISO Xfmr
	LAMP	POWER									LAMP	POWER							
S12P	YEL/GRN	GRAY	1	74	6.6	18	118.8	0.62	45W	S12Q	YEL/GRN	TAN	1	72	6.6	14.9	98.34	0.73	45W
S22P	TAN	YELLOW	2	133	6.6	31.1	205.26	0.65	100W	S22Q	TAN	GREEN	2	115	6.6	23.1	152.46	0.75	100W
S32P	GREEN	ORANGE	3	168	6.6	32.1	211.86	0.79	100W	S32Q	GREEN	YELLOW	3	150	6.6	26.3	173.58	0.86	100W
S42P	YELLOW	BROWN	4	190	6.6	36.5	240.9	0.79	200W	S42Q	YELLOW	BROWN	4	189	6.6	36.2	238.92	0.79	200W
M12P	VIOLET	GREEN	2	105	6.6	25.7	169.62	0.62	100W	M12Q	TAN	GREEN	2	115	6.6	23.1	152.46	0.75	100W
M22P	GREEN	ORANGE	4	158	6.6	34.9	230.34	0.69	200W	M22Q	YELLOW	BROWN	4	189	6.6	36.2	238.92	0.79	200W
M32P	GRAY	YELLOW	6	255	6.6	61.9	408.54	0.62	300W	M32Q	GREEN	YELLOW	6	276	6.6	53.2	351.12	0.79	300W
M42P	GREEN	BROWN	8	323	6.6	78.4	517.44	0.62	300W	M42Q	YELLOW	BROWN	8	356	6.6	67.1	442.86	0.80	300W
L12P	GREEN	ORANGE	3	166	6.6	30.6	201.96	0.82	100W	L12Q	GREEN	YELLOW	3	152	6.6	26.7	176.22	0.86	100W
L22P	GREEN	ORANGE	6	307	6.6	62.7	413.82	0.74	300W	L22Q	GREEN	YELLOW	6	275	6.6	53	349.8	0.79	300W
L32P	GREEN	ORANGE	9	448	6.6	94	620.4	0.72	500W	L32Q	GREEN	YELLOW	9	402	6.6	79.7	526.02	0.76	500W
L42P	GREEN	ORANGE	12	581	6.6	120	792	0.73	500W	L42Q	GREEN	YELLOW	12	529	6.6	102.4	675.84	0.78	500W

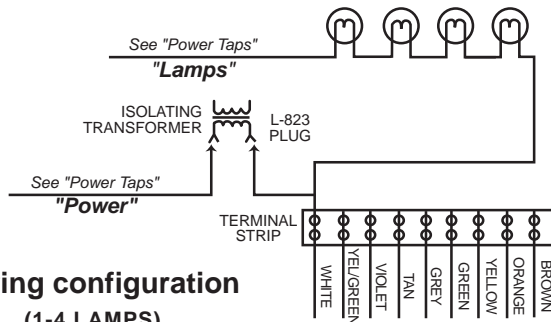

Wiring configuration
(1-4 LAMPS)

(Factory setting may vary slightly from the diagram.)

Only Lumacurves are backed by a
3 Year Warranty!
 Contact customer service for details.

Copyright 2009 by STANDARD SIGNS, INC. ALL RIGHT RESERVED.

STANDARD SIGNS, INC.

3190 East 65th Street, Cleveland, Ohio 44127, USA
 Phone: 800.258.1997 / 216.341-5611 Fax: 216.341.0652 www.lumacurve.com

Warning! For maintenance of previously installed equipment only!
 This system has not been certified to meet the latest FAA Advisory Circular 150/5345-44H

LUMACURVE PARTS LIST

Style 2 Lighting Systems

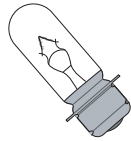

Incandescent
 T10P 6.6A/45W lamps
 (Shown below)

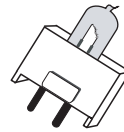

Quartz
 45W/EXM lamps
 (See Quartz insert)

Experience our exclusive "Wait-Less" service!
 Call by 10AM, complete signs & parts ship same day!
 No extra charge! Call 800.258.1997

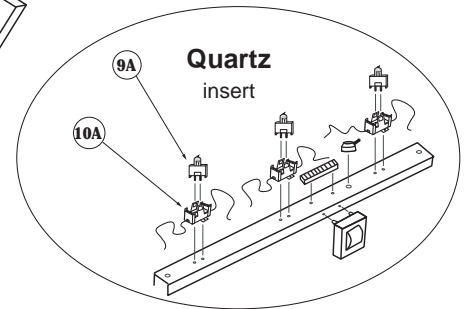

Item	Description
1. 340/345	Turn Fasteners
2. *CLT-2	Cover
3. *CLT-3	Base
4. *CLT-4	End Panel
5. *CLT-5	Legend Panel ¹
6. *CLT-6	Multi-Mode Insert
6A. *CLT-6A	Panel Spacer ²
7. *7-A	Face Insert Channel ¹
8. *8-A	Lamp Socket Channel
9. 6.6/T10P	45W Incandescent Lamp
9A. 45W EXM	45W EXM Quartz Lamp
10. 400	Prefocus Socket
10A. 501	Quartz Socket
11. 480	Cable Clamp
12. 420	Terminal Strip
13. 410	Current Transformer
14. CLT-19	Tether
15. 130	Slipfitter
16. *140	Frangible Coupling (6" long)
17. 430	Cord & Plug
18. 15	Floor Flange

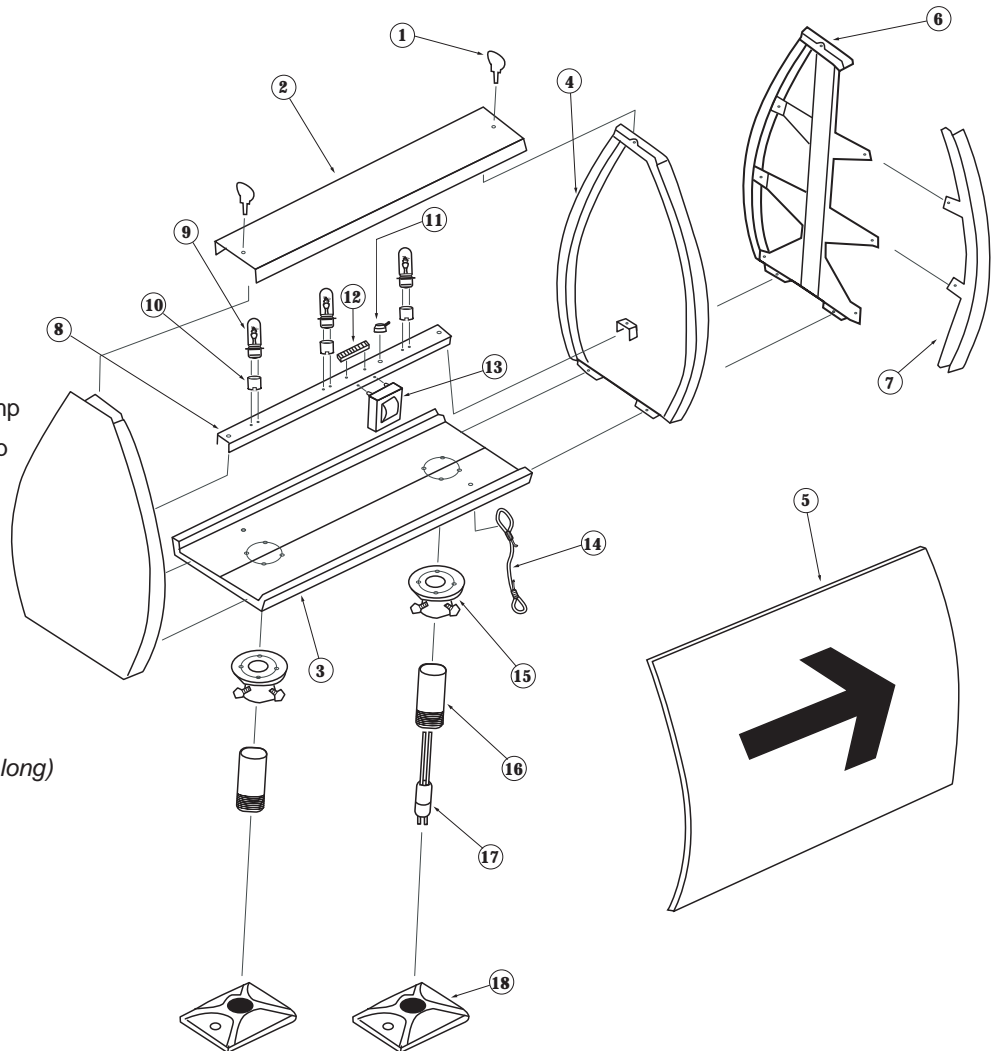

To help in placing your order:

*Prefix part number with one of the following sign sizes: "S" (small/ size 1), "M" (medium/ size 2), "L" (large/ size 3 & 5)

1 Specify one of the following sign types: L-858Y ("Y"ellow), L-858R ("R"ed), L-858L ("L"ocation), or Blank/ Black

2 Size 3 only, 2 per module-not pictured